



Induction Counter Units

Item: _____
 Quantity: _____
 Project: _____
 Approval: _____
 Date: _____

Induction Counter Units

Models:

- GIU-3.5 (SH/BA 3500) GIU-5.0 (SH/BA 5000)



Model GIU 3.5

How Induction Works:

Although induction seems magical in how it works, there is a scientific explanation.

1. An alternating current in an induction coil produces an alternating magnetic field
2. This magnetic field is instantly transferred and concentrated to the cooking vessel
3. This concentrated magnetic energy in the cooking vessel causes it to heat up and start cooking
4. When the vessel is removed from the heat source, the induction unit automatically shuts off

Standard Features:

- Compact table top design with stainless steel body and high impact ceramic glass top
- Sloped, easy to see front panel with adjustable control for easy operation
- Integral cooling fan keeps electronics cool, discharging from rear with protective air deflectors preventing hot exhaust to be pulled back into unit
- Removable, reusable easy to clean air intake filter
- 6' (1829mm) cord and plug supplied (60 cycle units only)
- "Flat Design", compact high performance electronics allow for low unit heights
- Instant energy transmission to the pan
- Available in either 3.5kW or 5.0kW
- Thermostatically controlled overheat sensor shuts the unit off to prevent damage from pans cooking dry
- Induction technology transfers heat to the pan, not to the surrounding air, allowing for cool operation
- Innovated new technology for pan detection; RTCS is an internal control software development matching speed, capability and performance.
 - R – Real Time
 - T – Temperature
 - C – Control
 - S – System
- Electronic output limitation continually monitors the energy transfer to the pan, helping to ensure the most efficient energy transfer possible.

Specifications:

Shall be a Garland Induction Unit model GIU-3.5 with a total kW rating of 3.5 kW or model GIU-5.0 with a total kW rating of 5.0 kW. Built with a robust stainless steel casting with a ceran glass work top. Compact powerful electronic system for years of reliable service. Overheat sensors prevent damage of the unit if pan is run dry. Easy to operate rotary switch with 1 to 12 scale. Units to come in 208V or 240V power (specify at the time of order) with integral cord and plug.

Note: Induction cooking requires magnetic pots and pans to work effectively.



Conforms to UL-197 & NSF-4
 Certified to CAN/CSA
 C22.2 NO. 109 VDE EN60335-2-38

Garland Commercial Industries, LLC
 185 East South Street
 Freeland, PA 18224
 Phone: (570) 636-1000
 Fax: (570) 636-3903

Garland Commercial Ranges Ltd
 1177 Kamato Road,
 Mississauga, Ontario
 L4W 1X4 CANADA
 Phone: 905-624-0260
 Fax: 905-624-5669

Enodis UK LTD
 Swallowfield Way,
 Hayes, Middlesex
 UB3 1DQ ENGLAND
 Telephone: 081-561-0433
 Fax: 081-848-0041

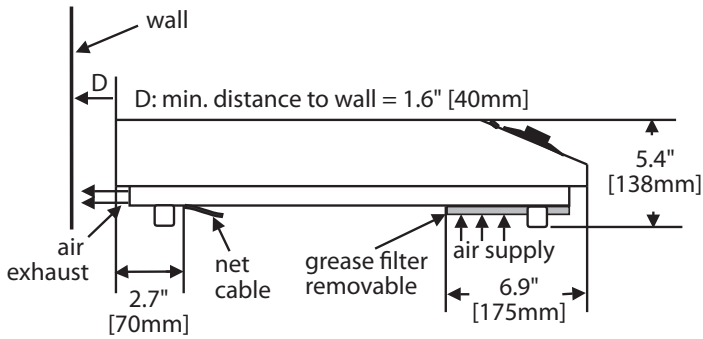

Enodis®

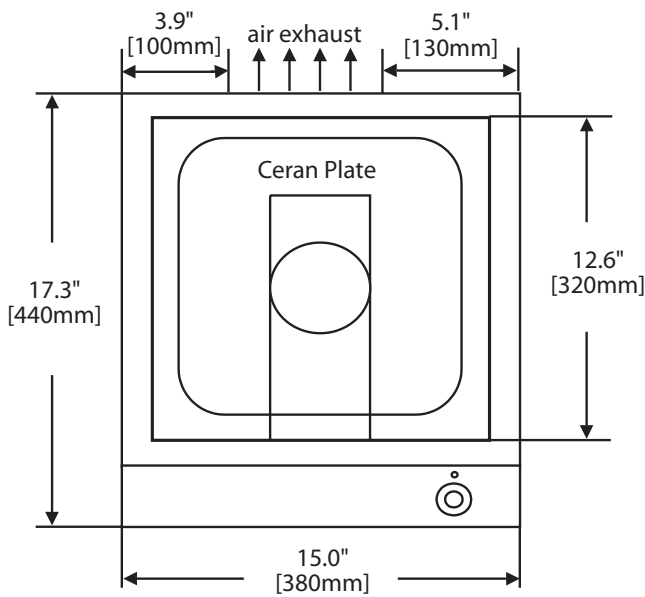
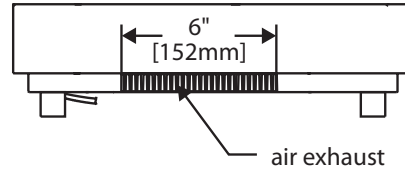

view A: air exhaust



PLUG CONFIGURATIONS:

Model	Electrical Characteristics	Plug
GIU-3.5	208V/60Hz/1Ø 240V/60Hz/1Ø	 NEMA 6-20P
GIU-5.0	208V/60Hz/3Ø	 NEMA 15-20P

Electrical Loading:

Model	Watts	208/60/1	208/60/3	240/60/1
GIU-3.5	3500	16 amp	N/A	14 amp
GIU-5.0	5000	N/A	14 amp	N/A

Form# GIU-3.5/5.0 (SH/BA 3500/5000) (05/07)