

PROglass 1 Under Counter Glass Washer



PROglass 1

The PROglass 1 features class leading specification and construction including a wash and rinse system using anti-blockage upper and lower rotating arms, an anti vacuum valve and micro filter. Ideal for pubs, clubs and small restaurants this cost effective and efficient work horse provides excellent washing results, meeting all user needs, handling a wide range of washing requirements including glasses up to a maximum height of 205mm.

PROglass 1 Under Counter Glass Washer Features

- Single phase
- Manual Control Panel
- Rinse temperature interlock
- WRAS approved to category 3
- 30 Racks per hour
- Rinse aid & detergent injectors
- Hot or Cold Fill
- Plastic wash and rinse arms
- S/Steel Micro filtration system
- Door Micro-switch
- Anti Vacuum valve
- Manual Self Cleaning System
- Clearance Height: 215mm
- Double skin door

OPTIONAL EXTRAS

- Drain Pump
- In-built water softener

PROglass 1 Under Counter Glass Washer

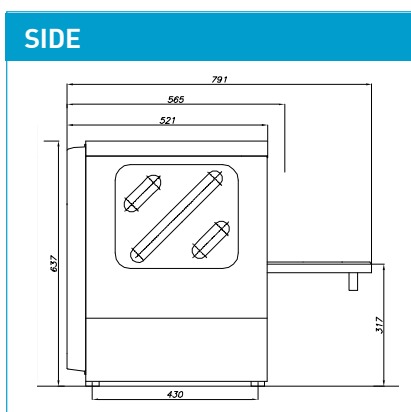
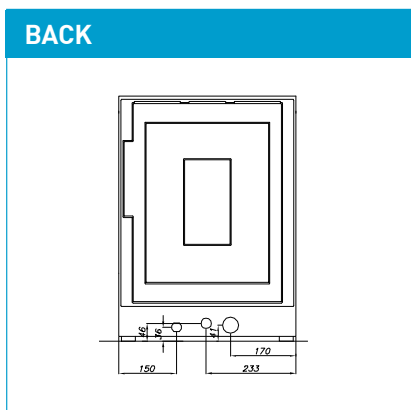
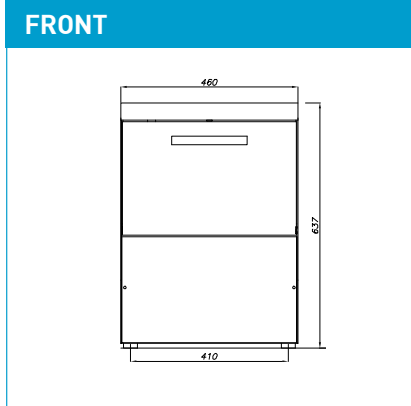

PROglass 1

The PROglass 1 features class leading specification and construction including a wash and rinse system using anti-blockage upper and lower rotating arms, an anti vacuum valve and micro filter. Ideal for pubs, clubs and small restaurants this cost effective and efficient work horse provides excellent washing results, meeting all user needs, handling a wide range of washing requirements including glasses up to a maximum height of 215mm.

Dimensions

Width: 460mm
Depth: 520mm
Height: 635mm

Packed Dimensions

Width: 570mm
Depth: 610mm
Height: 730mm

Rack Dimensions

Rack 400x400mm

Rack output per hour

30

Water Inlet / Outlet Dimensions

Water inlet: 3/4 BSP
Water outlet (diameter): 35mm

Wash Cycle (sec)

120

Power Requirements (50Hz)

230V

Wash Clearance Height

215mm

Total Power

2.8kw

Water Consumption per cycle

2 litres

Pump Power

0.37kw

Booster Heater (kW)

2.5kw

Tank Details

Capacity: 13 litres
Heater: 2kw
Booster / Rinse Tank Capacity: 6 litres

Nett / Gross Weight

34 / 38 kg

Other Models in this range:



PROglass 2



PROglass 3



PROglass 4



All Comenda warewashing products are CE approved.



Dawson MMP Ltd, Wath Road, Elsecar, Barnsley, South Yorkshire S74 8HJ
t: 01226 350450 e: info@dawsonmmp.co.uk w: www.dawsonmmp.co.uk

